

SECTION A-A

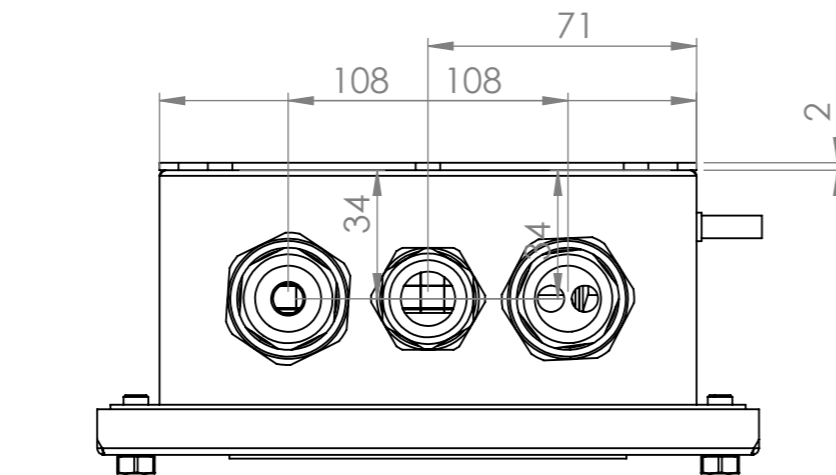

ITEM NO.	DESCRIPTION	PartNo	QTY.
1	TEF 105815xx JB	3149	1
2	Lid for JB	3125	1
3	GASKET FOR LID JB	50030081	1
4	Label for TEF 1054 ind.	50091268	1
5	SLOTTED BOLT M5x12	51012033	4
6	Connector M25	1567	1
7	Pressure nut M25 Ø17,5mm	50792018	1
8	Gasket EPM for Xenon searchlight	50030140	1
9	Washer Ø23/19x1	50799113	2
10	Terminal UK35	50281404	2
11	Ground terminal block PT 4 PE	50281452	2
12	Terminal PT 4	50281426	10
13	Endplate D-ST 4	50281176	3
14	End stopper E-NS-35-N	50281014	2
15	Plug-in bridge FBS 2-6	50281421	1
16	Cross-connection FBS 3-6	50281434	1
17	TERMINAL RAIL SS35 133MM	2771	1
18	Cable gland E704/3C/M25	6143993	1
19	Lock Nut M32	7957005	1
20	LOCK NUT M20	7957003	2
21	LOCK NUT M25	7957004	2
22	Cable Gland Exe: E204/622 M20/C1/9mm (Ø9,0-14,3mm)	6222010	1
23	Cable Gland Exe: E204/622 M20/C2/9mm (Ø6,0-10,0mm)	6222020	1
24	Cable Gland Exe: E204/622 M32/E1/9mm (Ø20,0-26,5mm)	6223210	1
25	O-Ring	50000013	1
26	Label for marking of terminals	50281350	12

REVISIONS			
REV.	DESCRIPTION	DATE	SIGN
A	One terminal added	28.11.2011	GL
B	Changed terminal blocks	03.12.2021	BKF
C	Corrected part no cable gland, changed from Autocad (2D) to Solidworks (3D)	29.09.2022	CKR
D	M25 gland and Connector M25 changed places	27.12.2023	ARS

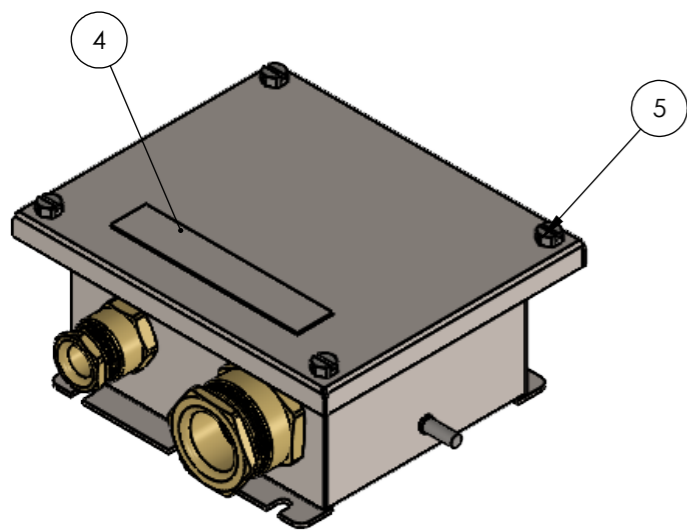

R. STAHL TRANBERG AS
 www.stahl-tranberg.com
 Strandsvingen 6, N-4032 Stavanger, Norway
 info.no-st@r-stahl.com
 Luhrtoppen 2, N-1470 Lørenskog, Norway
 info.no-os@r-stahl.com

Projection



Unless otherwise specified:
 Dimensions are in mm.
 Tolerances according to
 ISO 2768-M

Junction Box for bridge- and direct operated
 Xenon Searchlight
 Part No: 4643

Assembly Drawing

Drw. no.:	Rev.
600A103604	D
Subst. for:	Format
Subst. by:	A3
Scale: 1:2	
Date: 22.02.2008	
Design: CKR	

The information contained in this drawing is the sole property of R. Stahl Tranberg AS. Any reproduction in part or as a whole without the written permission of R. Stahl Tranberg AS is prohibited.