

# TRANBERG® LIGHTING

HML-ISO 35 Daylight Signalling Lamp

Safe Area



The new HML-ISO 35 offers you unbeatable advantages which not only facilitate operating and maintenance but also convince in handling and security at the same time.

Quote from the SOLAS (Safety of Life at Sea) (1997) Regulations: "all ships of over 150 tons gross tonnage, when engaged on International voyages, shall have onboard an efficient daylight signalling lamp which shall not be solely dependant upon the

ship's main source of electrical power."

## Application

- The handheld signalling light can be used on all vessels, for ship to ship signalling using Morse Code.
- HML-ISO 35 can also be used as a torch light due to its continuous light function

## Features and benefits

- Toughened front glass
- Rubber sealing
- Quick fastening rubber
- Sighting device
- Micro switch for left- and right hander
- Halogen lamp
- Connection cable =5m
- SOS function
- Permanent light function
- This device is built at least according to requirements of ABS, BV, DNV, GL, LR, PRS
- ABS carrying case with battery
- Battery Charger
- Spare lamps (3 pcs)
- Red, green and blue filters included
- 2 flush mount power outlets included



## Technical Data

Protection class to EN 60 529:	IP56
Material housing:	Plastic (ABS)
Color:	Black
Voltage:	12 / 24 V
Wattage:	35
Luminous intensity:	108.900 cd
Range 1 lux at target:	330 m
Signal-range:	Day: 3,4 km Night: 21,4 km
Lamp:	Halogen incandescent lamp
Parabolic mirror / reflector:	Glass, Ø 150 mm
Light color:	Constant
Average lamp life:	4,000 h
Tamb:	-25 -to +55 °C

## Approvals and certificates

DNV GL SE MEDB0000206, MEDD00000J3,  
ISO 25861, EN 60945,  
IMO Res. MSC. 95, ships of 150 GT at least  
acc. to SOLAS

## R. STAHL TRANBERG AS

Main office | Strandsvingen 6 | N-4032 Stavanger, Norway | T +47 51 57 89 00 | E info.no-st@r-stahl.com | stahl-tranberg.com  
Oslo office | Lührtoppen 2 | N-1470 Lørenskog, Norway | T +47 24 08 44 10 | E info.no-os@r-stahl.com | stahl-tranberg.com

TRANBERG STAHL

THE STRONGEST LINK.

# TRANBERG® LIGHTING

HML-ISO 35 Daylight Signalling Lamp

Safe Area

Description	Dimensions	Weight	Part No.
HML-ISO 35 Daylight Signalling Lamp w/ carrying case	525 x 435 x 220 (mm)	12 kg.	2519225100

Accessories	Weight	Part No.
Power outlet, 10A, IP56, Flush mounting. For hand held signalling light	0,2 kg.	2519225101
Power outlet, 10A, IP56, Bulkhead mounting. For handheld signalling light	0,3 kg.	2519225102

## Dimensions

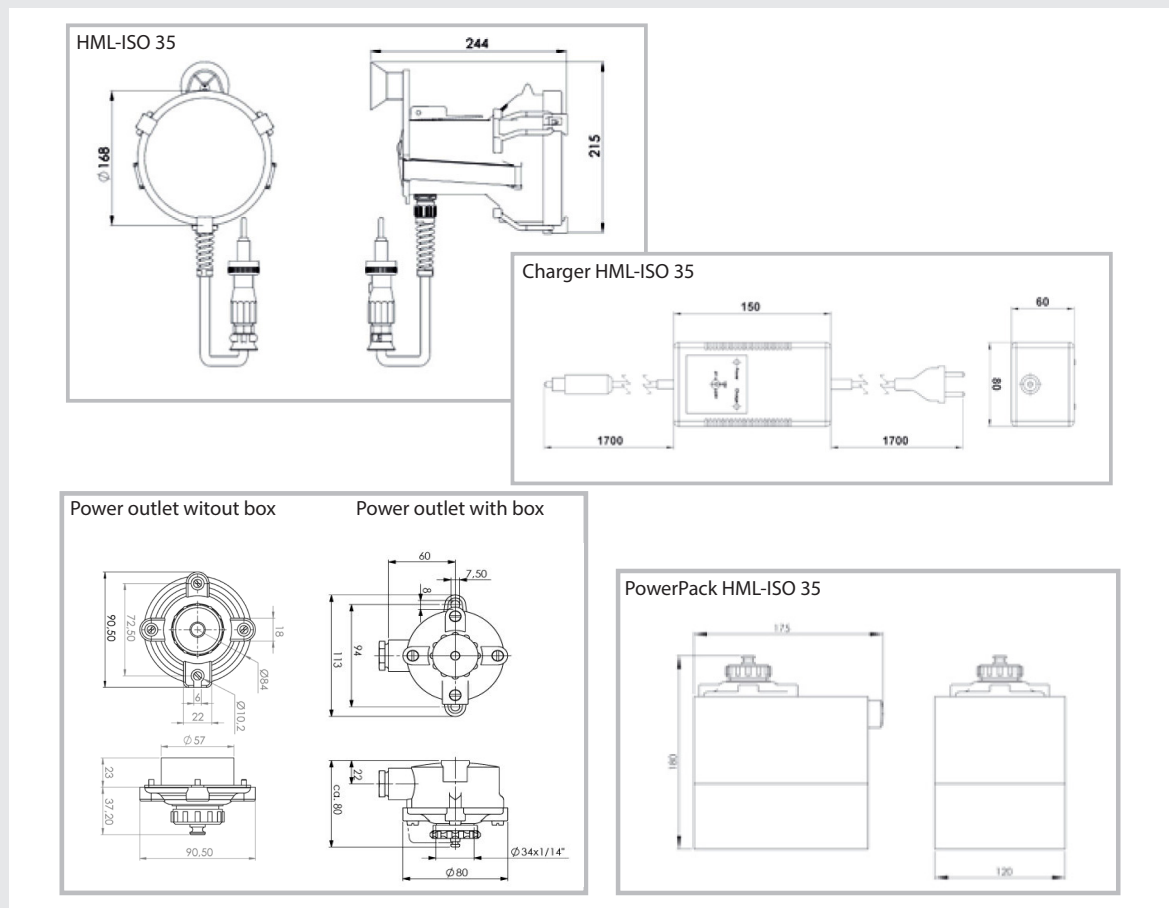

R. STAHL TRANBERG AS

Main office | Strandsvingen 6 | N-4032 Stavanger, Norway | T +47 51 57 89 00 | E info.no-st@r-stahl.com | stahl-tranberg.com

Oslo office | Lührtoppen 2 | N-1470 Lørenskog, Norway | T +47 24 08 44 10 | E info.no-os@r-stahl.com | stahl-tranberg.com