

SUPERTYFON® AT 150/330 with Valve Unit TV 784

A high-power whistle according to IMO for vessels up to 200 m in length



AT 150/330 Housing Complete

Ref. no. 24510052

Valve Unit TV 784

Ref. no. 24510043

Horn AT 150/330

Ref. no. 32170884

General Information

Before "COLREG 1972" (the International Regulations for Preventing Collisions at Sea), a popular practice was to use low-pitched tones even for smaller vessels. In other words, the principle of a low tone for large vessels was not followed with sufficient stringency.

According to the IMO regulations, the very low tones are strictly reserved for the largest ships. For middle-sized and smaller vessels, there are rather wide limits as to the choice of frequencies. Preference has been given to signals which, even at some distance, have capability to be heard. For vessels of 75 to 200m, Whistles with frequencies between 130 and 350 Hz are appropriate.

Positioning Whistles

For an all-round radiation and a limited noise level from the ship's whistles at the listening posts, the positioning of the ship's whistles is very important. For further information regarding installation regulations and "Combined Systems", see our leaflet "IMO Regulations, KSM 265E".

Valve Unit

The **VALVE UNIT TV 784** has a good air flow section, thermostatic heating, exchangeable choke flanges and filters. The apparatus is fitted with two coils for normal and emergency operation and lanyard as standard (see separate leaflet KSM 264).

Installation

SUPERTYFON AT 150/330 is to be fixed with three M10 bolts to an outrigger or similar construction. To avoid functional trouble blow the supply pipe thoroughly clean before connecting to the signalling whistle. If the pipe line above deck is longer than 100m, a primary **FILTERTP 15/2** should be installed at the foot of the mast to protect the signalling apparatus from water condensate and rust particles. This filter is recommended to be drained regularly, approximately once a month.

Technical Data

Frequency: 330 Hz (340 Hz*)

Sound Pressure Level (1m):

Total: 148 dB

1/3 octave IMO limit: 138 dB

Air consumption: 20–30 l/s

Air supply pressure with choke regulation:

0,6–3 MPa (6–30 bar)

Electric power:

Thermostat heating: 24 W

Valve: 27 W

Weight: 11,5 kg

*Complementary frequency available together with 330 Hz.

For wiring diagram: see Valve Unit TV 784, KSM 264.

AT 150/330: Spare Parts and Dimensions

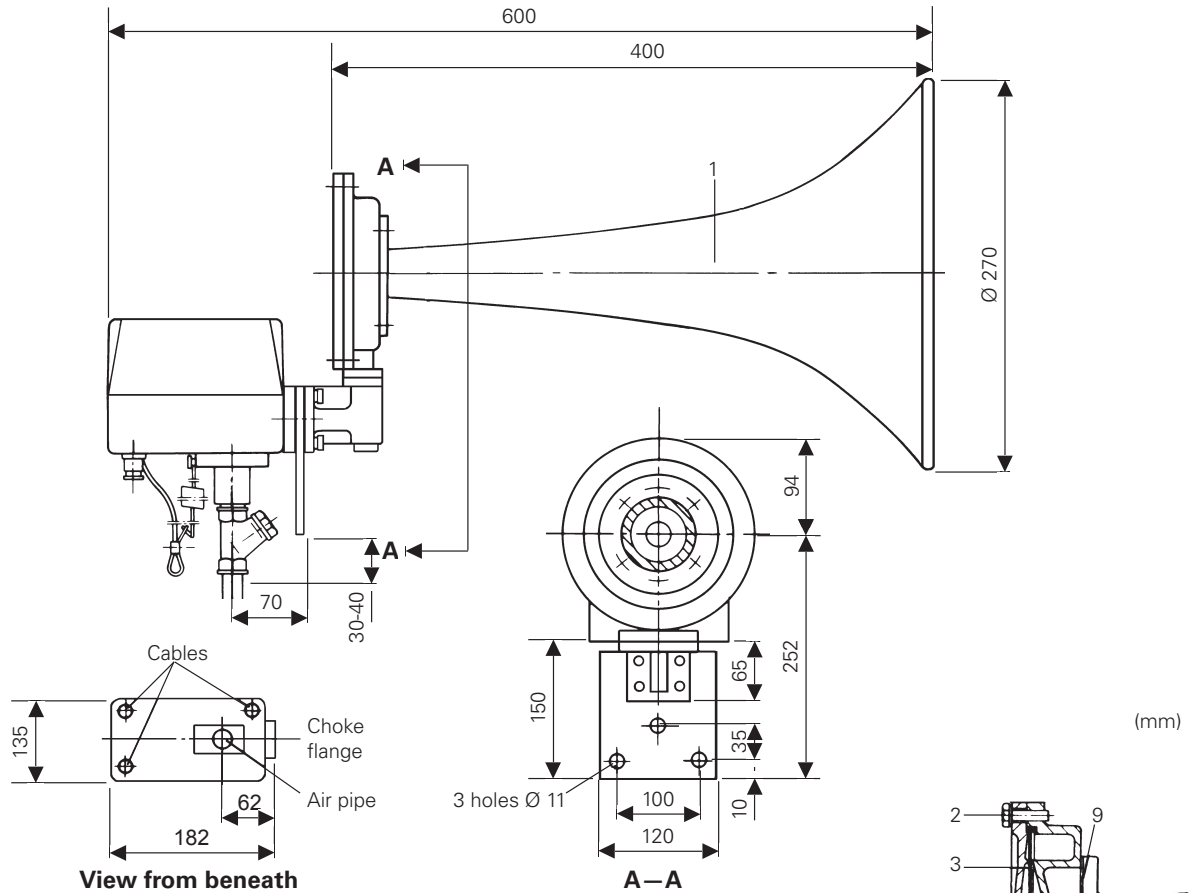

Spare Parts AT 150/330			
No.	Name	Material	Ref. no.
1	Horn AT 150/330	Glass-fibre reinf. polyester	2170884
2	Screw M6S 8 x 16	Stainl. steel	20801121
3	Diaphragm KM 150 AT compl. with O-rings	Titan/Nitrile rubber	21758006
4	Screw M6S 8 x 30	Stainl. steel	20801124
5	Choke flange (state pressure)	Brass	21768201
6	Filter	Brass	32170418
7	Screw M6S 8 x 25	Stainl. steel	20801123
8	Housing 150 AT	Brass	21754100
9	Packing 120/36 x 1	Nitrile rubber	37710245
10	Packing 62 x 62 x 1	Nitrile rubber	21765037
11	Packing 80 x 39 x 1	Nitrile rubber	37710278

Spare parts can be obtained from Kockum Sonics or their agents. When ordering, please, give working pressure, reference number and part name. Spare parts for valve unit, see Valve Unit TV 784, KSM 264.

Pipe line dimensions		
Working pressure MPa (overpressure)	Length of pipe metres	Inside diam. of pipe, mm (inches)
below 2.0	Max. 150	Min. 25 (1")*
	150 - 350	Min. 32 (1 1/4")*
above 2.0	Max. 150	Min. 19 (3/4")*
	150 - 350	Min. 25 (1")*

*Converting muff necessary for connection to signal apparatus

Air Pressure Choking

The basic condition for good performance and reliable function is the appropriate air pressure activating the diaphragm.

When ordering, please state the working pressure. If the connection pipe is dimensioned in accordance with the recommendations (see table), the pressure gauge reading at the air receiver in the engine room is adequate for choice of choke.